



(19) **United States**

(12) **Patent Application Publication**

Mochizuki et al.

(10) **Pub. No.: US 2002/0105267 A1**

(43) **Pub. Date: Aug. 8, 2002**

(54) **DISPLAY DEVICE**

Publication Classification

(76) Inventors: **Noritaka Mochizuki**, Kanagawa (JP);
Ryuji Tokuda, Kanagawa (JP);
Michitaka Setani, Kanagawa (JP);
Masanori Sakuranaga, Kanagawa (JP);
Hikaru Hoshi, Kanagawa (JP)

(51) **Int. Cl.⁷** **H01J 63/04**
(52) **U.S. Cl.** **313/512; 313/506**

(57) **ABSTRACT**

Correspondence Address:
FITZPATRICK CELLA HARPER & SCINTO
30 ROCKEFELLER PLAZA
NEW YORK, NY 10112 (US)

(21) Appl. No.: **09/993,672**

(22) Filed: **Nov. 27, 2001**

(30) **Foreign Application Priority Data**

Dec. 5, 2000	(JP)	370647/2000
Dec. 27, 2000	(JP)	398283/2000
Mar. 6, 2001	(JP)	062055/2001
Jun. 22, 2001	(JP)	189722/2001
Oct. 2, 2001	(JP)	306539/2001

A display device comprises a transparent substrate, a plurality of electroluminescent elements arranged on the transparent substrate, transparent members respectively covering the electroluminescent elements, and reflection films formed respectively on the surfaces of the transparent members. Each of the electroluminescent elements is formed by sequentially laying a transparent electrode, an electroluminescent layer and a reflector electrode on the transparent substrate. Each of the transparent members has a profile of a frustum of pyramid or cone, or partly has a curved surface showing a positive curvature and has a curved surface showing a negative curvature at the portion held in contact with the transparent substrate.

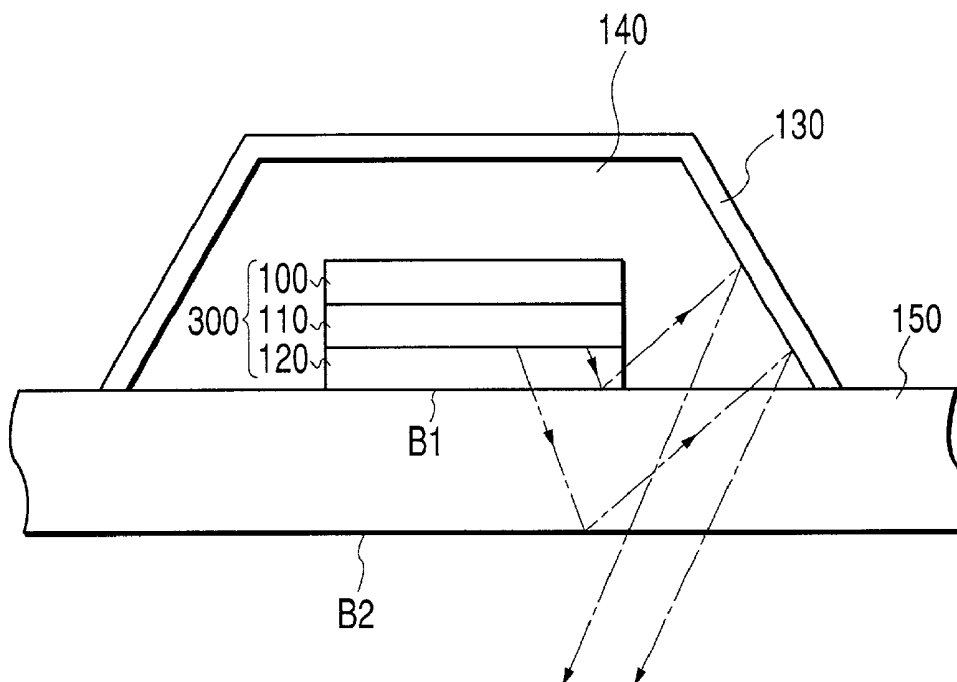

FIG. 1
PRIOR ART

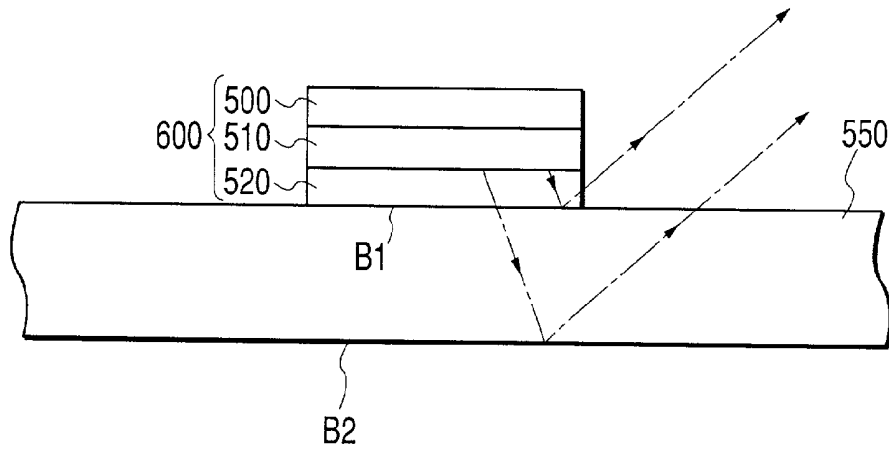

FIG. 2
PRIOR ART

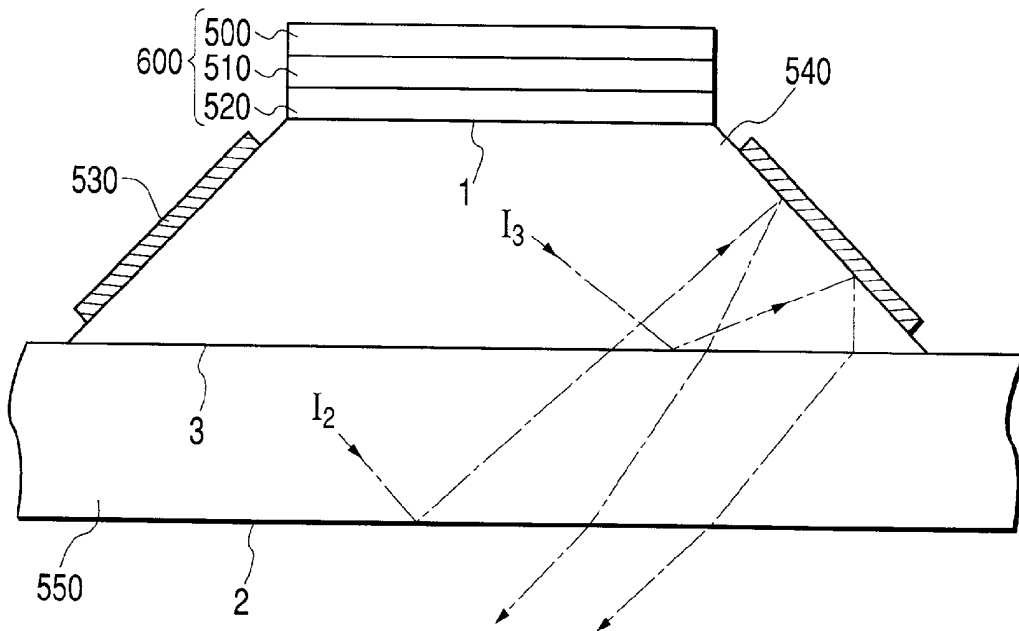

FIG. 3

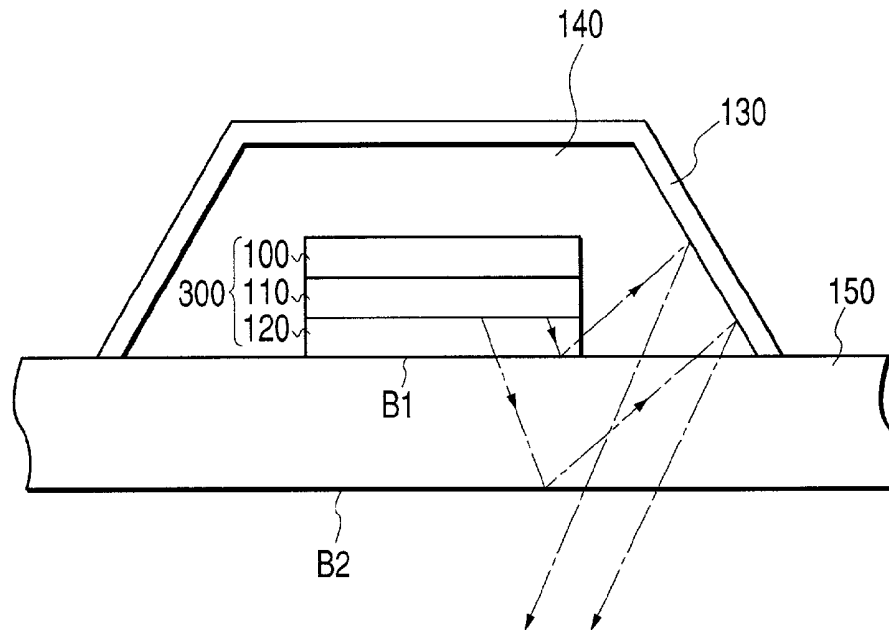

FIG. 4A

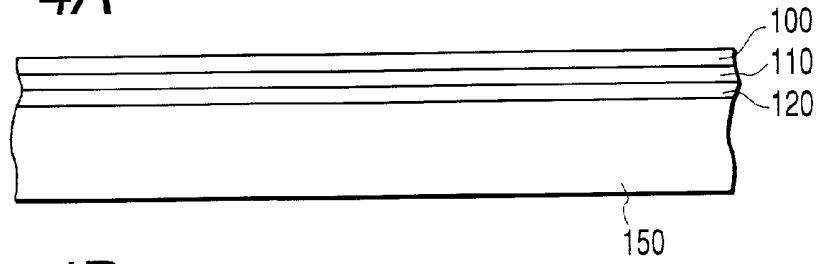

FIG. 4B

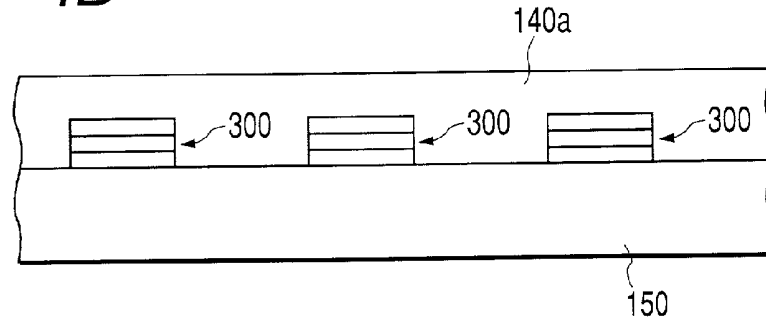

FIG. 4C

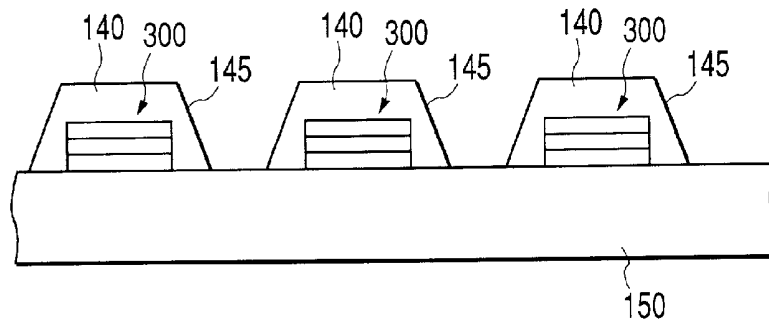

FIG. 4D

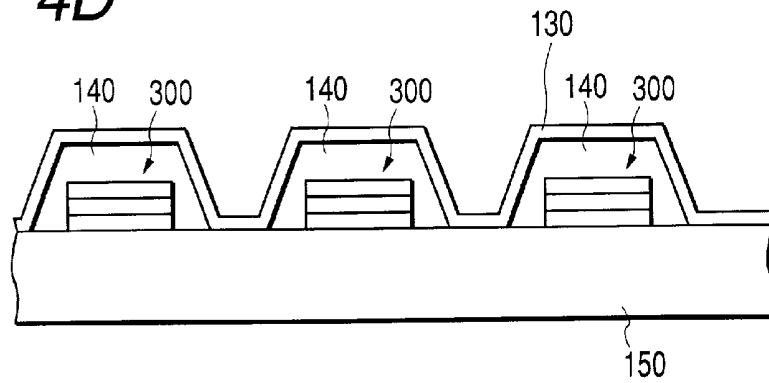

FIG. 5

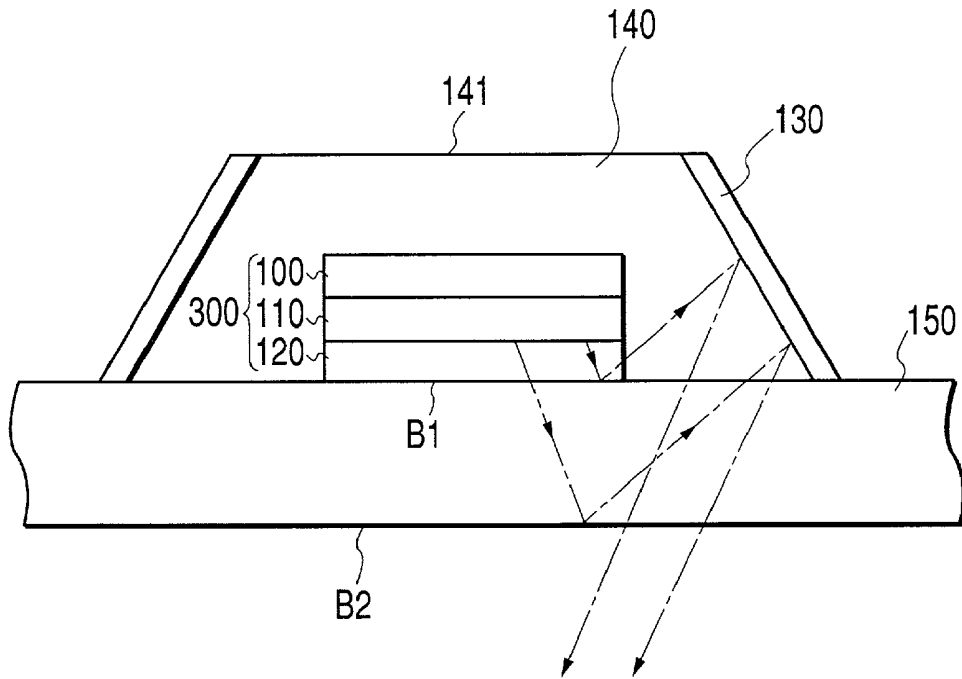

FIG. 6A

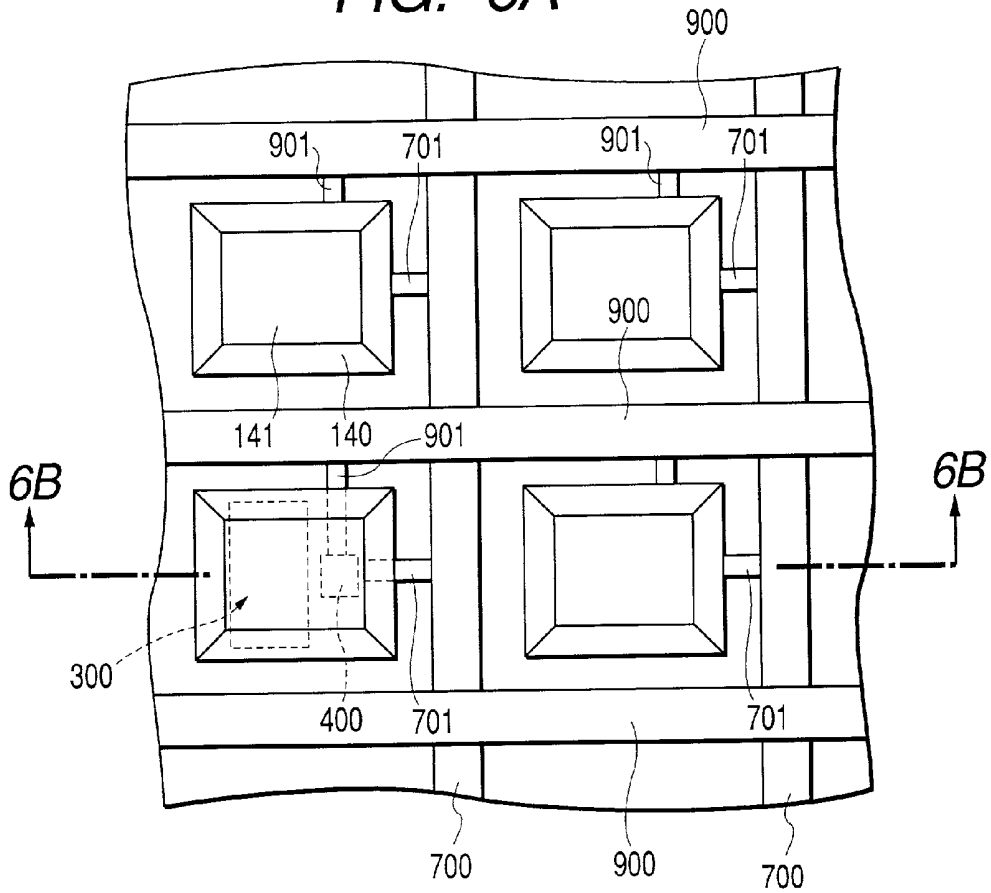

FIG. 6B

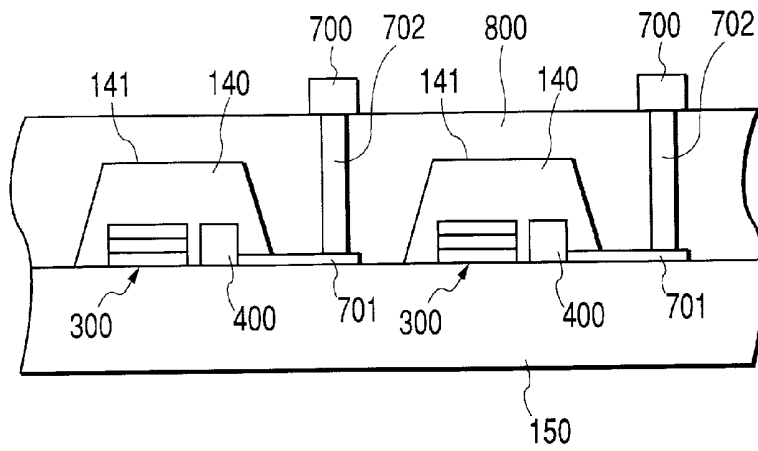

FIG. 7

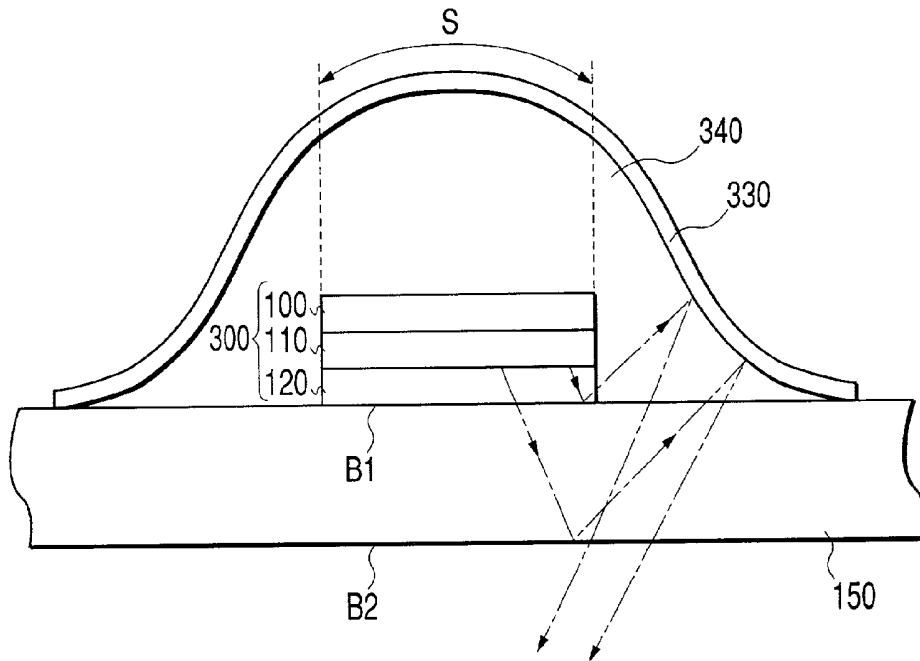

FIG. 8

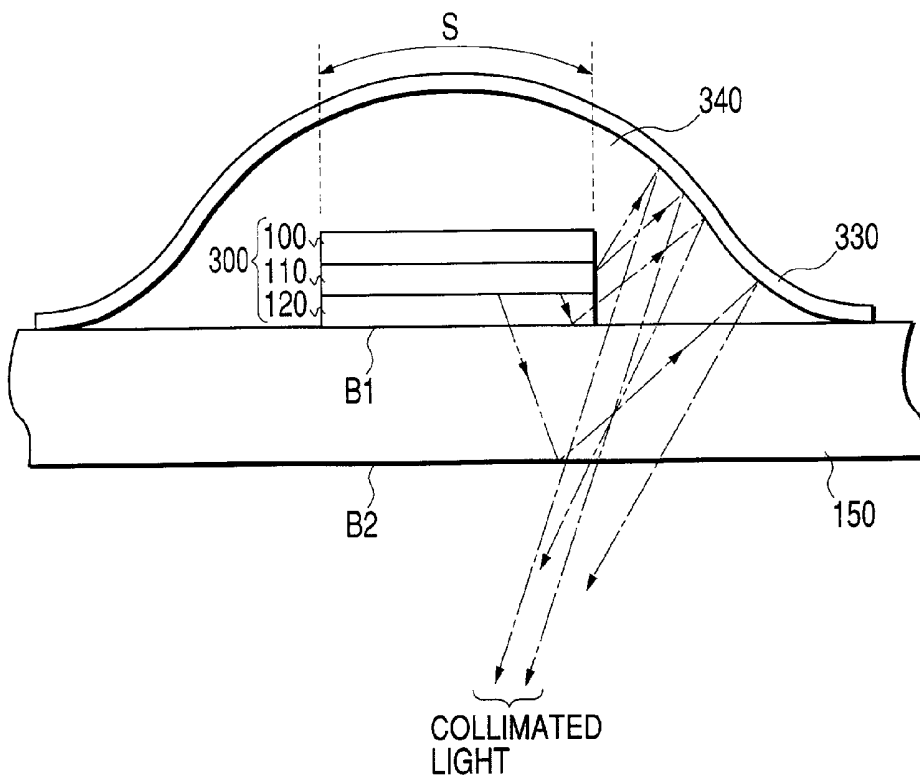

FIG. 9

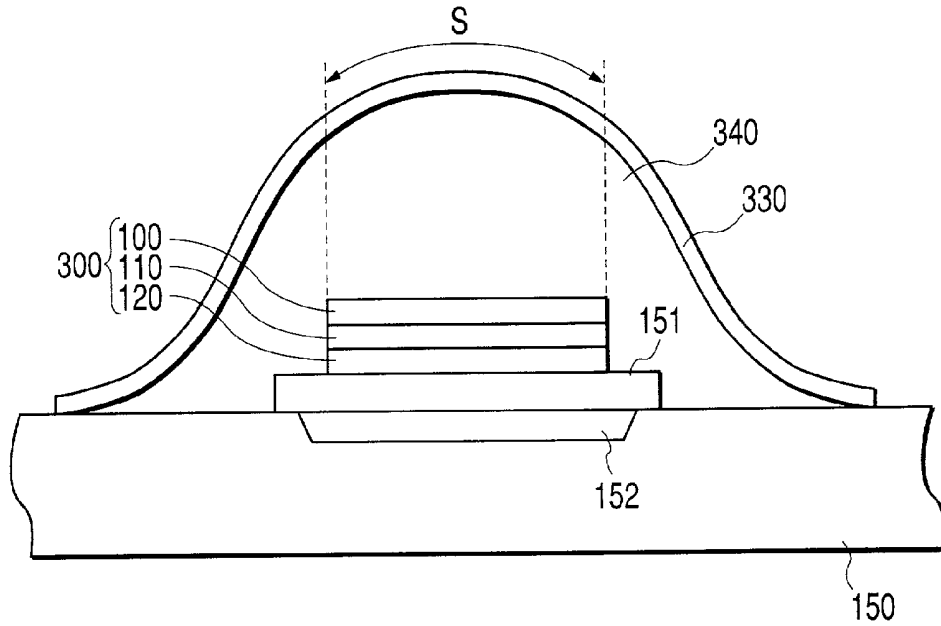

FIG. 10

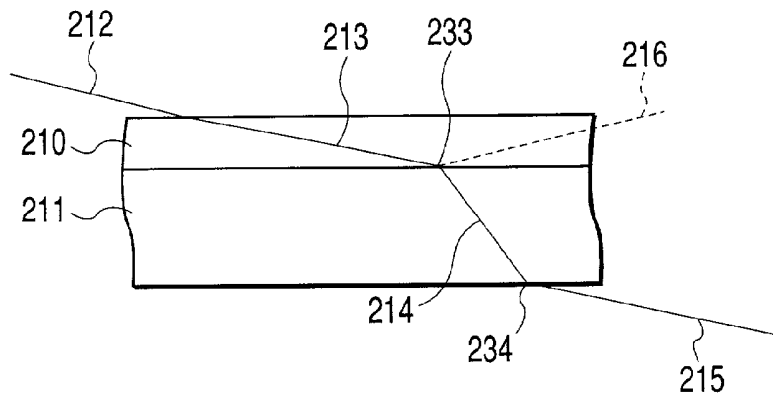

FIG. 11

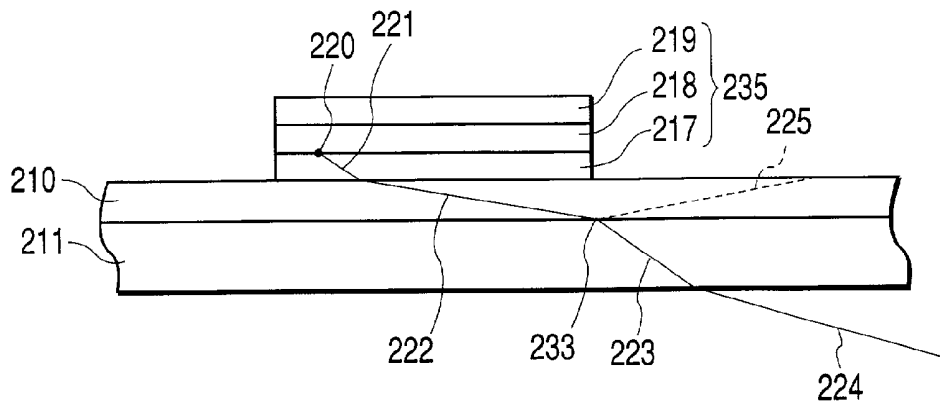

FIG. 12

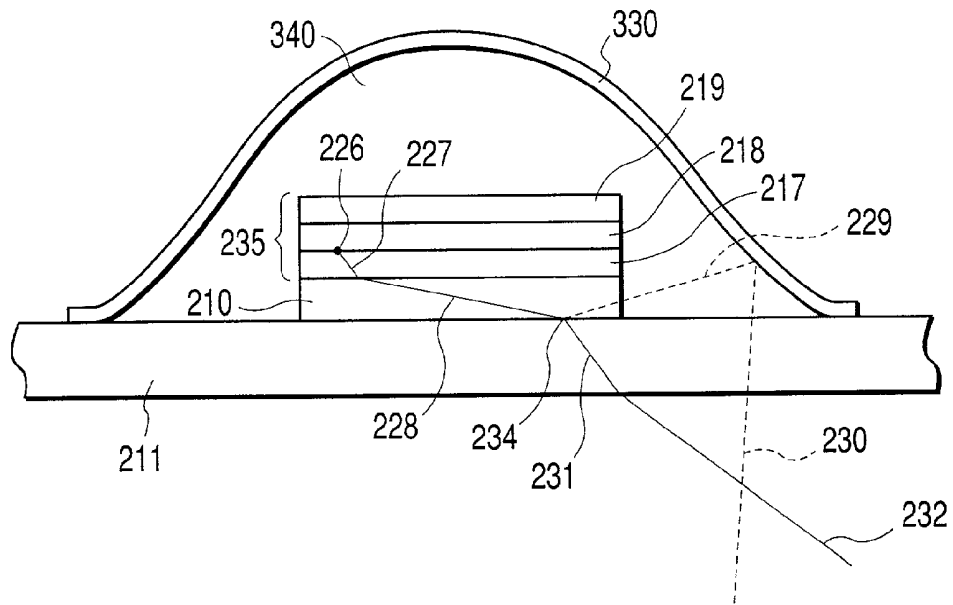

FIG. 13

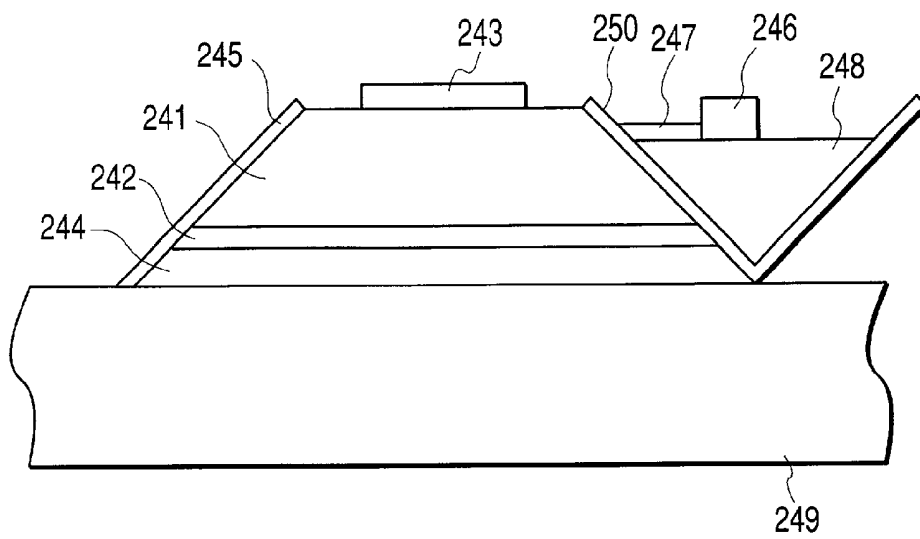

FIG. 16

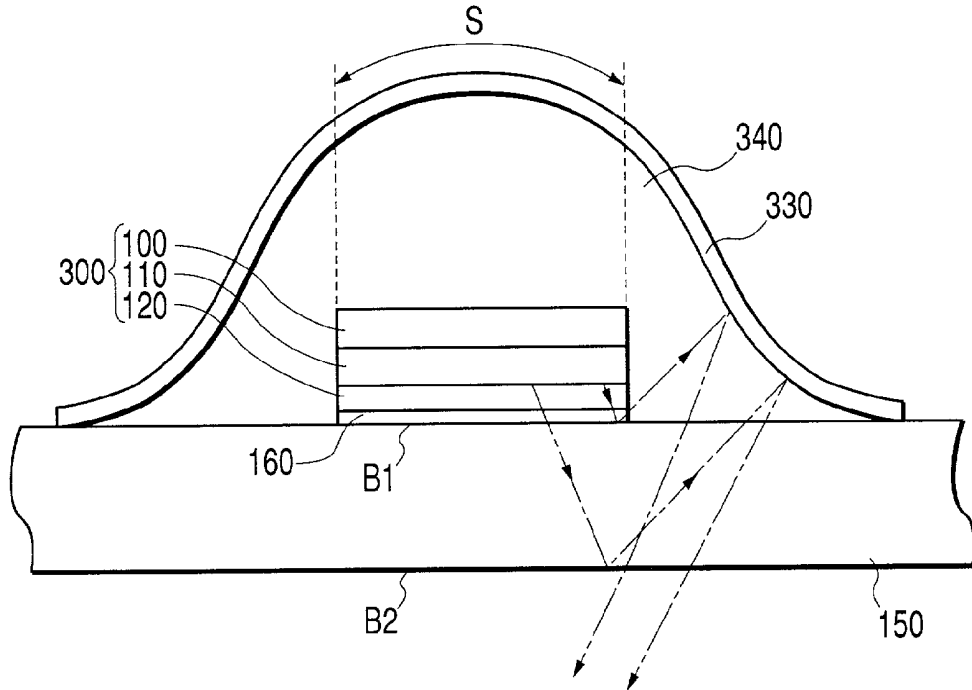

FIG. 17

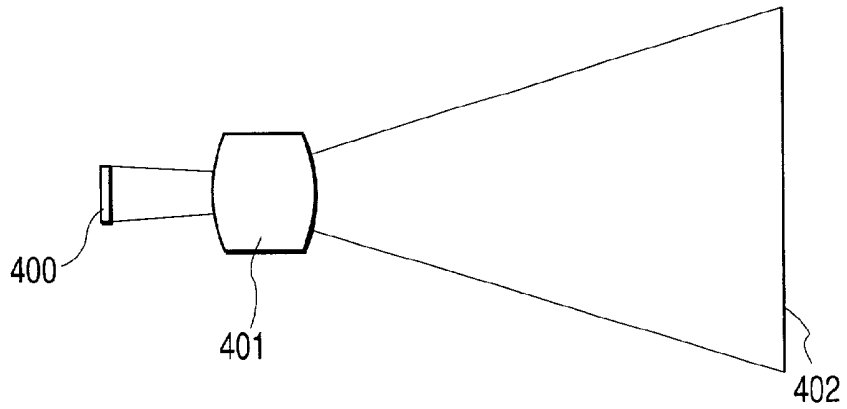

FIG. 18

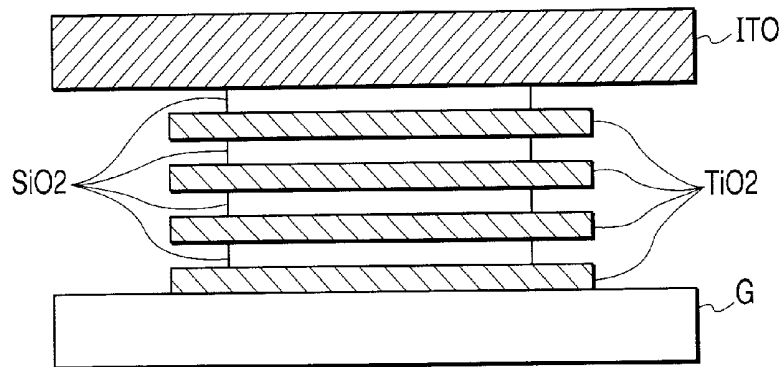

FIG. 19

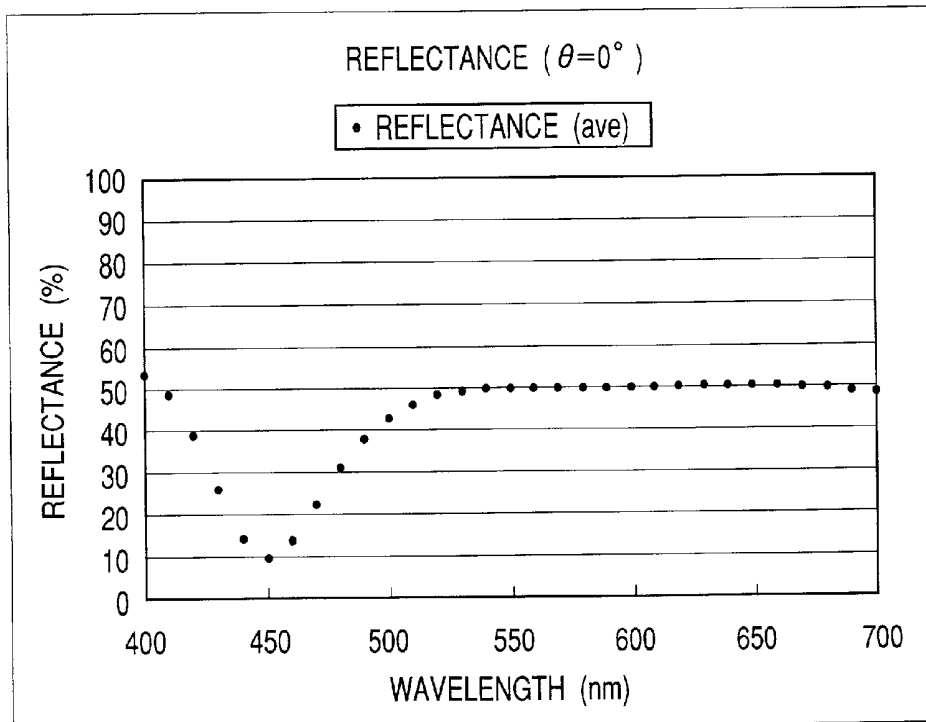

FIG. 20A

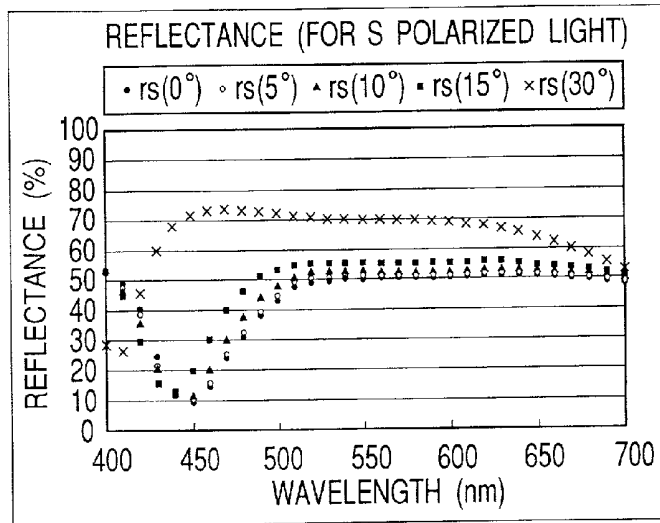

FIG. 20B

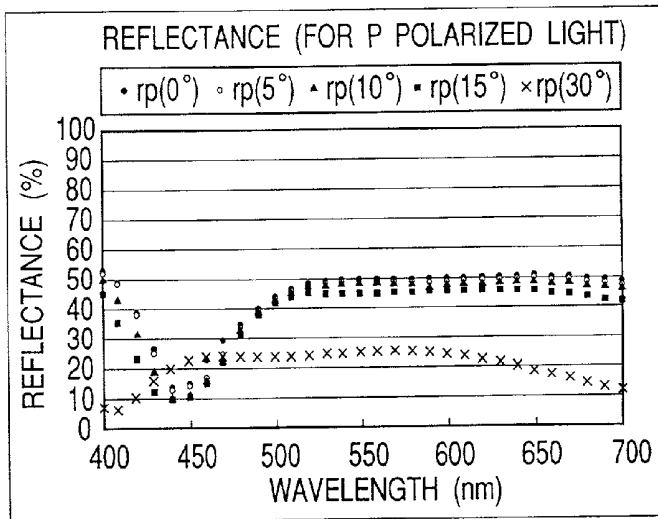

FIG. 20C

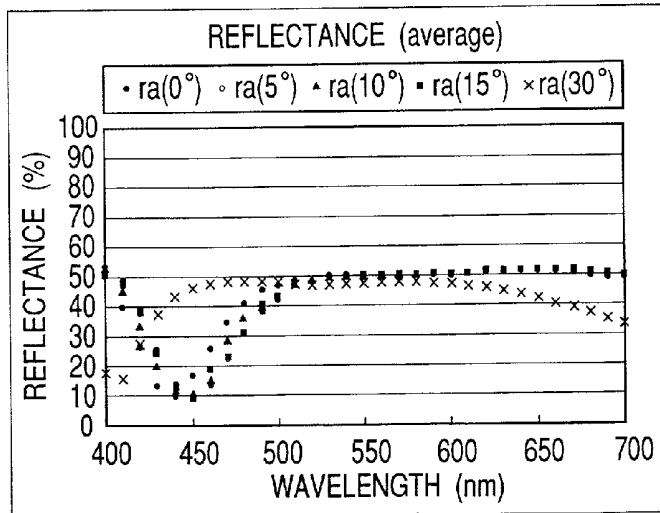

FIG. 21

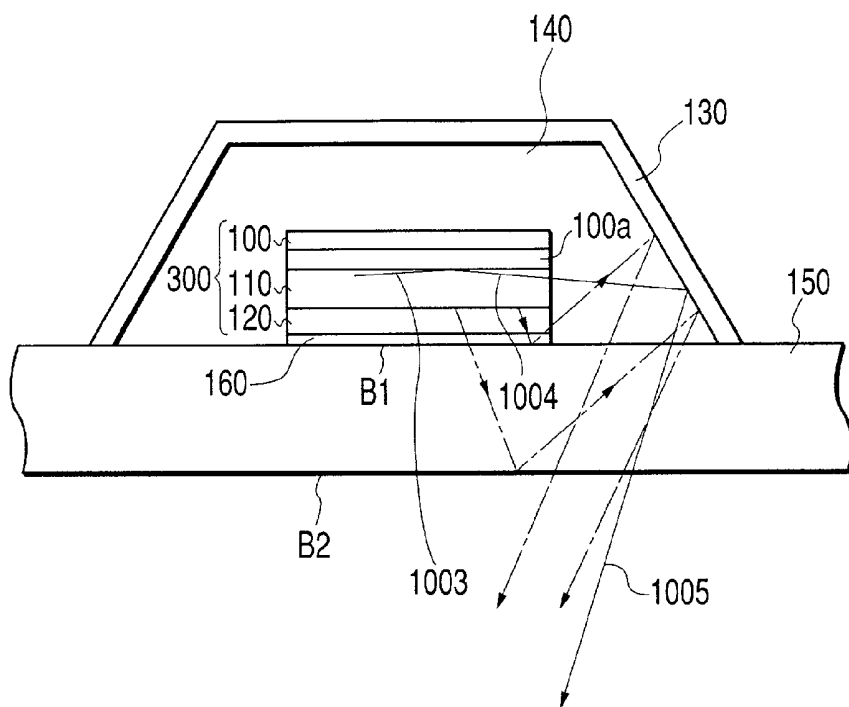
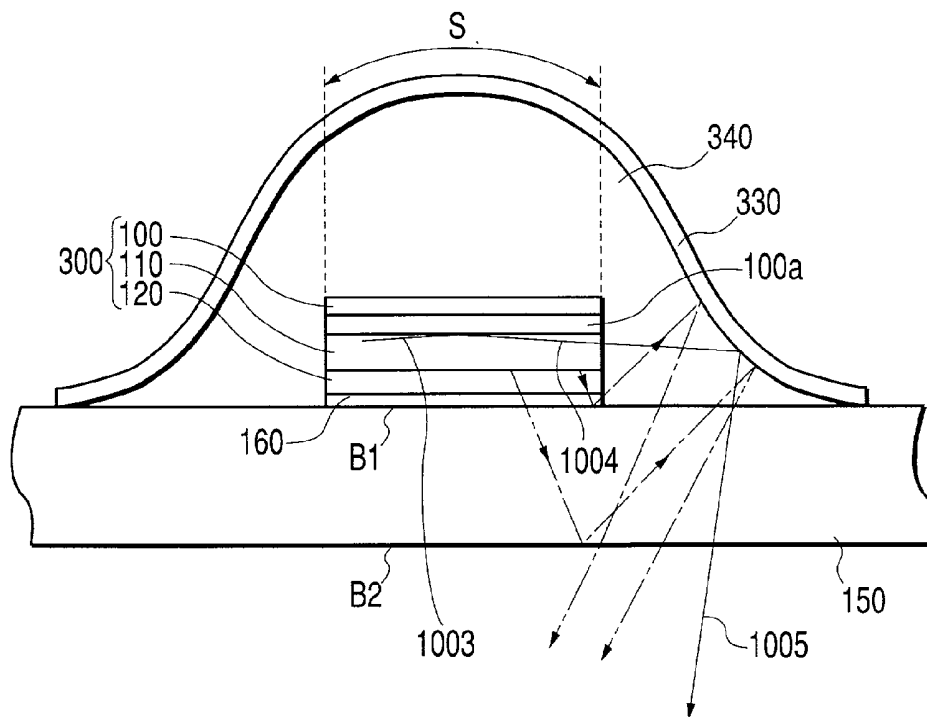

FIG. 22



DISPLAY DEVICE

BACKGROUND OF THE INVENTION

[0001] 1. Field of the Invention

[0002] This invention relates to a display device. More particularly, it relates to a display device adapted to highly efficiently take out light emitted from electroluminescent (EL) elements that operate as so many display pixels to the outside.

[0003] 2. Related Background Art

[0004] Display devices comprising a plurality of EL elements arranged two-dimensionally on a same substrate are known. However, in any known display devices, the ratio of the quantity of light that can be externally taken out to the total quantity of light emitted from each of the EL elements is not very large.

[0005] FIG. 1 of the accompanying drawings is a schematic cross sectional view of an EL element of a known display device, illustrating its basic structure. Referring to FIG. 1, the EL element 600 is formed by sequentially laying a transparent electrode 520, an electroluminescent (EL) layer 510 and a reflector electrode 500 on a transparent substrate 550 in the above mentioned order. Light emitted from the EL layer 510 is totally reflected at the interface B1 of the transparent substrate 550 and the transparent electrode 520 and the interface B2 of the transparent substrate 550 and ambient air. If the refractive index of the transparent electrode 520 is 1.8 and that of the transparent substrate 550 is 1.5, the quantity of light confined within the EL element 600 due to total reflection at the interface B1 is about 51% of the total quantity of light emitted from the EL element 600. On the other hand, the quantity of light confined within the EL element 600 due to total reflection at the interface B2 is about 32% of the total quantity of light emitted from the EL element 600. Therefore, the quantity of light that can be externally taken out from the transparent substrate 550 is only about 17% of the total quantity of emitted light.

[0006] Meanwhile, Optics Letters, Mar. 15 (1997) pp. 396 to 398, discloses an EL element realized by adding a transparent member having a trapezoidal cross section to the above described basic structure, from which light can be taken out at an improved efficiency. FIG. 2 of the accompanying drawings is a schematic cross sectional view of such an EL element. In FIG. 2, the components that are same as those of FIG. 1 are denoted respectively by the same reference symbols.

[0007] Referring to FIG. 2, the EL element 600 has a sandwich structure where an EL layer 510 is sandwiched between a reflector electrode 500 and a transparent electrode 520. The EL element 600 is laid on a transparent member 540 having a trapezoidal cross section and formed on a transparent substrate 550. When such EL elements are applied to a two-dimensional display device, the transparent member 540 of each EL element is typically realized in the form of a frustum of quadrangular pyramid. Then, a reflection film 530 is formed on the slopes of the transparent member 540.

[0008] With an EL element 600 having a configuration as shown in FIG. 2, no total reflection takes place at the interface 1 when the refractive index of the transparent

member 540 is made greater than that of the transparent electrode. On the other hand, if total reflection occurs at the interface 2 of the transparent substrate 550 and ambient air, light I_2 totally reflected by the interface 2 is reflected again by the reflection film 530 and taken out of the transparent substrate 550 into ambient air. Similarly, if total reflection occurs at the interface 3 of the transparent member 540 and the transparent substrate 550, light I_3 totally reflected by the interface 3 is reflected again by the reflection film 530 and taken out of the transparent member 540. It may be needless to note that light emitted from the EL layer 510, transmitted through the transparent electrode 520 and directly reflected by the reflection film 530 goes out of the transparent substrate 550 into ambient air. Therefore, the above described arrangement allows light emitted from the EL layer 510 to be highly efficiently taken out to the outside.

[0009] However, if the reflection film 530 formed on the slopes of the transparent member 540 is made of metal in the above described EL element, it needs to be formed so as not to contact the transparent electrode 520 and the reflector electrode 500. It is not easy to form such a reflection film. Additionally, although not shown in FIG. 2, the sandwich structure sandwiching the EL layer 510 needs to be covered by a protection film in order to prolong the service life of the EL element 600. Then, such a protection film has to be prepared independently from the process of manufacturing the transparent member 540 to increase the number of total manufacturing steps and baffle effects for reducing the manufacturing cost.

SUMMARY OF THE INVENTION

[0010] In view of the above identified circumstances, it is therefore the object of the present invention to provide a display device that is free from the problems of the conventional technology and adapted to highly efficiently take out light emitted from the EL layers thereof to the outside, while it can be manufactured at low cost.

[0011] According to the invention, the above object is achieved by providing a display device comprising:

[0012] a transparent substrate;

[0013] a plurality of electroluminescent elements arranged on the transparent substrate, each of the electroluminescent elements being formed by sequentially laying a transparent electrode, an electroluminescent layer and a reflector electrode on the transparent substrate;

[0014] transparent members having a profile of a frustum of pyramid or cone and respectively covering the electroluminescent elements; and

[0015] reflection films formed respectively on the surfaces of the transparent members.

[0016] In another aspect of the invention, there is also provided a display device comprising:

[0017] a transparent substrate;

[0018] a plurality of electroluminescent elements arranged on the transparent substrate, each of the electroluminescent elements being formed by sequentially laying a transparent electrode, an electroluminescent layer and a reflector electrode on the transparent substrate;

[0019] transparent members respectively covering the electroluminescent elements, each of the transparent members partly having a curved surface showing a positive curvature, a part thereof held in contact with the transparent substrate having a curved surface showing a negative curvature; and

[0020] reflection films formed respectively on the surfaces of the transparent members.

BRIEF DESCRIPTION OF THE DRAWINGS

[0021] FIG. 1 is a schematic cross sectional view of a known EL element.

[0022] FIG. 2 is a schematic cross sectional view of another known EL element.

[0023] FIG. 3 is a schematic cross sectional view of an electroluminescent element operating as a pixel in the first embodiment of display device according to the invention.

[0024] FIGS. 4A, 4B, 4C and 4D are partial schematic cross sectional views of the embodiment of display device of FIG. 3, illustrating different manufacturing steps.

[0025] FIG. 5 is a schematic cross sectional view of an electroluminescent element operating as a pixel in the second embodiment of display device according to the invention.

[0026] FIGS. 6A and 6B are a partial schematic plan view and a corresponding partial schematic cross sectional view of the third embodiment of display device according to the invention.

[0027] FIG. 7 is a schematic cross sectional view of an electroluminescent element operating as a pixel in the fourth embodiment of display device according to the invention.

[0028] FIG. 8 is a schematic cross sectional view of an electroluminescent element operating as a pixel in the fifth embodiment of display device according to the invention.

[0029] FIG. 9 is a schematic cross sectional view of an electroluminescent element operating as a pixel in the sixth embodiment of display device according to the invention.

[0030] FIG. 10 is a partial cross sectional view of a silica aerogel film formed on a transparent substrate.

[0031] FIG. 11 is a schematic cross sectional view of an electroluminescent element formed on a transparent substrate carrying a silica aerogel film formed thereon.

[0032] FIG. 12 is a schematic cross sectional view of an electroluminescent element having a silica aerogel film formed on a transparent substrate and operating as a pixel in the seventh embodiment of display device according to the invention.

[0033] FIG. 13 is a schematic cross sectional view of an electroluminescent element having a low refractive index light transmitting film formed on a transparent substrate and operating as a pixel in the eighth embodiment of display device according to the invention.

[0034] FIG. 14 is schematic cross sectional view similar to FIG. 13 but illustrating the behavior of rays of light in the electroluminescent element.

[0035] FIG. 15 is a schematic cross sectional view of an electroluminescent element having a half mirror formed on a transparent substrate and operating as a pixel in the ninth embodiment of display device according to the invention.

[0036] FIG. 16 is a schematic cross sectional view of an electroluminescent element having a half mirror formed on a transparent substrate and operating as a pixel in the tenth embodiment of display device according to the invention.

[0037] FIG. 17 is a conceptual illustration of a projector realized by using a display device shown in FIG. 15 or FIG. 16.

[0038] FIG. 18 is a schematic cross sectional view of a half mirror structure having eight layers.

[0039] FIG. 19 is a graph illustrating the reflectance of the half mirror structure of FIG. 18.

[0040] FIGS. 20A, 20B and 20C are graphs illustrating the reflectance of a half mirror structure having eight layers in different aspects.

[0041] FIG. 21 is a schematic cross sectional view of an electroluminescent element having a light absorbing layer formed on a transparent substrate and operating as a pixel in the eleventh embodiment of display device according to the invention.

[0042] FIG. 22 is a schematic cross sectional view of an electroluminescent element having a light absorbing layer formed on a transparent substrate and operating as a pixel in the twelfth embodiment of display device according to the invention.

DESCRIPTION OF THE PREFERRED EMBODIMENTS

[0043] Now, the present invention will be described by referring to the accompanying drawings that illustrate preferred embodiments of the invention.

[0044] FIG. 3 is a schematic cross sectional view of an electroluminescent (EL) element operating as a pixel in the first embodiment of display device according to the invention. Referring to FIG. 3, the EL element 300 is formed by sequentially laying a transparent electrode 120, an electroluminescent (EL) layer 110 and a reflector electrode 100 on a transparent substrate 150 in the above mentioned order. Additionally, a transparent member 140 having a trapezoidal cross section is formed on the transparent substrate 150 to cover the EL element 300. In other words, the EL element 300 is protected from ambient air by the transparent member 140. A reflection film 130 is formed as coat on the entire surface of the transparent member 140.

[0045] The EL layer 110 of the EL element shown in FIG. 3 emits light as a voltage is applied between the reflector electrode 100 and the transparent electrode 120. Light emitted from the EL layer 110 is mostly transmitted through the transparent electrode 120 and the transparent substrate 150 and externally taken out.

[0046] On the other hand, a part of light emitted from the EL layer 110 is totally reflected by the interface B1 of the transparent electrode 120 and the transparent substrate 150. The totally reflected light is reflected by the reflection film 130 and transmitted through the transparent substrate 150 before it is externally taken out. While the totally reflected

light is refracted twice by the interface B1 and the interface B2, it is shown in FIG. 3 as if it proceeds straight for the purpose of simplicity.

[0047] Another part of light emitted from the EL layer 110 is refracted by the interface B1 and totally reflected by the interface B2 of the transparent substrate 150 and ambient air. However, the totally reflected light is also reflected by the reflection film 130 and transmitted through the transparent substrate 150 before it is externally taken out. In this way, light emitted from the EL element 300 is highly efficiently taken out to the outside.

[0048] While a single EL element is shown in FIG. 3, a plurality of identical EL elements are arranged two-dimensionally in the embodiment of display device. When the EL elements are arranged two-dimensionally, the transparent members are typically realized in the form of a frustum of quadrangular pyramid.

[0049] Now, the process of manufacturing EL elements will be described by referring to FIGS. 4A through 4D. FIGS. 4A through 4D are partial schematic cross sectional views of the embodiment of display device of FIG. 3, illustrating some of the EL elements in different manufacturing steps.

[0050] Firstly, as shown in FIG. 4A, a transparent electrode 120 typically made of ITO, an EL layer 110 made of an organic or inorganic material and a reflector electrode 100 made of metal film are sequentially formed on a transparent substrate 150 typically made of glass or plastic in the above mentioned order.

[0051] Then, the electrodes and the EL layer are removed by pattern etching except the necessary areas to produce EL elements 300 arranged in a manner as shown in FIG. 4B. Then, a transparent layer 140a is formed to cover the EL elements 300. The transparent layer 140a is typically made of titanium oxide.

[0052] Subsequently, the transparent layer 140a is partly removed by pattern etching to produce a plurality of transparent members 140, each having slopes 145 as shown in FIG. 4C, to completely cover the respective EL elements 300.

[0053] Finally, as shown in FIG. 4D, a reflection film 130 of metal or dielectric is formed on the entire surface of the transparent substrate 150 by deposition. In this way, a display device comprising a plurality of EL elements 300 formed on a transparent substrate is manufactured.

[0054] FIG. 5 is a schematic cross sectional view of an electroluminescent (EL) element operating as a pixel in the second embodiment of display device according to the invention. This embodiment differs from the first embodiment only in that the reflection film 130 is formed only on the slopes of the transparent members 140. In other words, no reflection film is formed on the top surface 141 of the transparent members 140. Otherwise, the second embodiment is same and identical with the first embodiment. Therefore, in FIG. 5, the components that are same as or similar to those of FIG. 3 are denoted respectively by the same reference symbols and will not be described any further.

[0055] Referring to FIG. 5, in this embodiment again, a part of light emitted from the EL layer 110 is totally reflected by the interface B1 of the transparent electrode 120 and the transparent substrate 150. The totally reflected light is then reflected by the reflection film 130 and transmitted through

the transparent substrate 150 before it is taken out into ambient air. While the light totally reflected by the reflection film 130 is refracted twice by the interface B1 and the interface B2, it is shown in FIG. 5 as if it proceeds straight for the purpose of simplicity. Since no reflection film is formed on the top surface 141 of the transparent member 140, this embodiment provides an advantage that heat emitted with light can be easily dissipated if compared with the first embodiment.

[0056] The second embodiment of display device is produced by removing the reflection film that has been formed on the entire surface of the transparent members 140 as shown in FIG. 4D from the top surfaces 141 thereof by photo-etching after the manufacturing steps shown in FIGS. 4A through 4D and described above by referring to the first embodiment.

[0057] FIGS. 6A and 6B are a partial schematic plan view and a corresponding partial schematic cross sectional view of the third embodiment of display device according to the invention. FIG. 6A is a partial schematic plan view and FIG. 6B is a schematic cross sectional view taken along line 6B-6B in FIG. 6A. In FIGS. 6A and 6B, the components that are same as or similar to those of FIGS. 3 through 5 are denoted respectively by the same reference symbols and will not be described any further.

[0058] In this embodiment, each EL element 300 and a corresponding drive element 400 such as TFT for driving the EL element 300 are covered by a transparent member 140. Note that the wires between each element 300 and the corresponding drive element 400, which may be a TFT, are not shown in FIGS. 6A and 6B for the purpose of simplicity. Each transparent member 140 is realized in the form of a frustum of quadrangular prism having a top surface 141. Therefore, each transparent member 140 shows a trapezoidal cross section. Although not shown in FIG. 6B, the surfaces of the transparent members 140 are covered by a reflection film as shown in FIG. 3 or FIG. 5.

[0059] In this embodiment, the gaps separating the plurality of transparent members 140 that are covered by a reflection film are filled with an insulating body 800 and row-directional wires 900 and column-directional wires 700 are formed on the insulating body 800. The drive element 400 connected to each EL element 300 is by turn connected to a column-directional wire 700 by way of an outgoing wire 701. The outgoing wire 701 and the column-directional wire 700 are connected by way of a through hole 702 through the insulating body 800. Similarly, the drive element 400 connected to each element 300 is also connected to a row-directional wire 900 by way of an outgoing wire 901. With the above described arrangement, the EL elements 300 of this embodiment of display device emit light as so many pixels of a two-dimensional display screen.

[0060] While each EL element 300 of FIGS. 6A and 6B is connected to a column-directional wire 700 and a row-directional wire 900 by way of a corresponding drive element 400, alternatively it may be directly connected to the wires without a drive element 400 interposed between them. While the transparent members have a profile of a frustum of quadrangular pyramid in the above description, they may alternatively have a profile of a frustum of cone. Still alternatively, the transparent members may have a profile of a part of a ball.

[0061] FIG. 7 is a schematic cross sectional view of an electroluminescent (EL) element operating as a pixel in the

fourth embodiment of display device according to the invention. In FIG. 7, the components that are same as or similar to those of FIG. 3 are denoted respectively by the same reference symbols and will not be described any further.

[0062] In this embodiment, the transparent members 340 are so formed as to show a profile of a part of a ball. More specifically, each transparent member 340 has a top section that shows a profile of a part of a ball with a positive curvature and a bottom section, or an outskirt section, that is connected to the transparent substrate 150 and shows a profile of a curved slope with a negative curvature. In other words, the transparent member 340 has a convex top section and a concave outskirt section. Then, the surface of each transparent member 340 is covered by a reflection film 330. The reflection film 330 operates as a concave mirror for the EL element 300.

[0063] Each transparent member 340 may be formed by causing a drop of hot and molten plastic to fall onto the corresponding EL element 300 and subsequently solidifying the molten plastic. The inclination of the outskirt section is determined as a function of the contact angle of the transparent substrate 150 and the liquefied transparent member 340. The inclination of the outskirt section may be controlled by pressing the semispherical transparent member 340 from the top before the latter is solidified.

[0064] In the EL element shown in FIG. 7, the EL layer 110 emits light when a voltage is applied between the reflector electrode 100 and the transparent electrode 120. Light emitted from the EL layer 110 is transmitted through the transparent electrode 120 and the transparent substrate 150 before it is externally taken out.

[0065] On the other hand, a part of light emitted from the EL layer 110 is totally reflected by the interface B1 of the transparent electrode 120 and the transparent substrate 150. The totally reflected light is reflected by the reflection film 330 and transmitted through the transparent substrate 150 before it is taken out into ambient air. While the totally reflected light is refracted twice by the interface B1 and the interface B2, it is shown in FIG. 7 as if it proceeds straight for the purpose of simplicity.

[0066] Another part of light emitted from the EL layer 110 is refracted by the interface B1 and totally reflected by the interface B2 of the transparent substrate 150 and ambient air. However, the totally reflected light is also reflected by the reflection film 330 and transmitted through the transparent substrate 150 before it is taken out into ambient air.

[0067] Almost no light gets to the top section S of the transparent member 340. Rays of light proceeding substantially perpendicularly relative to the end facets of the EL element 300 are not totally reflected by the interface B1 but transmitted through the transparent substrate 150 and taken out into ambient air. Thus, if the top section S is not accurately semispherical but distorted somewhat, it does not significantly affect the function of the EL element 300. In this way, light emitted from the EL element 300 is highly efficiently taken out to the outside.

[0068] FIG. 8 is a schematic cross sectional view of an electroluminescent (EL) element operating as a pixel in the fifth embodiment of display device according to the invention. This embodiment differs from the above described fourth embodiment only in that the focal plane of the concave mirror formed by the reflection film 330 is located inside the element EL element 300. Otherwise, this embodiment is identical with the fourth embodiment. Therefore, in

FIG. 8, the components that are same as or similar to those of FIG. 7 are denoted respectively by the same reference symbols and will not be described any further.

[0069] In this embodiment, rays of light emitted from the end facets of the EL layer 110 are reflected by the concave mirror section of the transparent member 340 to form a flux of parallel rays of light, which is then taken out to the outside through the transparent substrate 150. In the outskirt section of the transparent member 340, all the light reflected by the interfaces B1, B2 is reflected again before it is externally taken out into ambient air. Thus, light is externally taken out to a large proportion.

[0070] In this embodiment again, almost no light gets to the top section S of the transparent member 340. Rays of light proceeding substantially perpendicularly relative to the end facets of the EL element 300 are not totally reflected by the interface B1 but transmitted through the transparent substrate 150 and taken out into ambient air. Thus, if the top section S is not accurately semispherical but distorted somewhat, it does not significantly affect the function of the EL element 300.

[0071] While the outskirt section of the transparent member 340 is realized in the form of a curved surface with a negative curvature (concave surface) in either of the embodiments shown in FIGS. 7 and 8, an effect similar to that of FIG. 7 or 8 can be obtained when the transparent member 340 is made to show a profile having no such a concave surface, or a profile of a part of a ball such as a semispherical profile having only a positive curvature.

[0072] FIG. 9 is a schematic cross sectional view of an electroluminescent (EL) element operating as a pixel in the sixth embodiment of display device according to the invention. In FIG. 9, the components that are same as or similar to those of FIG. 7 are denoted respectively by the same reference symbols and will not be described any further.

[0073] In this embodiment, the transparent substrate 150 is provided with grooves 152, each having a size sufficiently covering an EL element 300. A thin transparent plate 151 typically made of titanium oxide (TiO_2) is formed on the groove 152. An EL element 300 is formed on the transparent plate 151. In other words, the inside of the groove 152 is a void and an air gap is formed between the transparent plate 151 and the substrate 150.

[0074] In this embodiment, light from the EL element 300 that is transmitted through transparent plate 151 and the groove 152 containing a void therein and strikes the substrate 150 is not totally reflected by the substrate 150. In other words, totally reflected light in the transparent substrate 150 will not be propagated into other pixels nor confined within the substrate 150. Therefore, light emitted from the EL element 300 is effectively taken out into ambient air by the reflector hemisphere formed by the transparent member 340 and the reflection film 330.

[0075] While the transparent member 340 has a profile of a part of a ball in FIG. 9, it may be replaced by a transparent member 140 having a profile of a frustum of quadrangular pyramid as shown in FIG. 3 or that of a frustum of cone.

[0076] Meanwhile, it may be conceivable to form a low refractive index film such as a silica aerogel film on the transparent substrate of a display device according to the invention in order to improve the efficiency of taking out light from the transparent substrate. Such arrangements will be discussed below.

[0077] FIG. 10 is a partial cross sectional view of a silica aerogel film 210 formed on a transparent substrate 211. Such a silica aerogel film 210 typically shows a refractive index of 1.03. Light 212 striking the silica aerogel film 210 from air is refracted by the interface of the silica aerogel film 210 and the transparent substrate 211 according to the Snell's law of refraction to become light 214. Light 214 is then emitted into air from the lower surface 234 of the transparent substrate 211 as light 215. Since the transparent substrate 211 is sandwiched between substances having respective refractive indexes that are lower than the refractive index of itself, no total reflection takes place in the transparent substrate 211. However, light 213 is reflected in the direction of regular reflection as a result of Fresnel reflection at the interface 233 to give rise to light 216. The intensity of light 216 increases as the angle of incidence of light 213 is reduced to become quasi-parallel relative to the transparent substrate 211.

[0078] FIG. 11 is a schematic cross sectional view of an electroluminescent (EL) element 235 formed on a transparent substrate 211 carrying a silica aerogel film 210 formed thereon. In FIG. 11, the components that are same as or similar to those of FIG. 10 are denoted respectively by the same reference symbols and will not be described any further.

[0079] Referring to FIG. 11, the EL element 235 is formed by sequentially laying a transparent electrode 217 typically made of ITO, an EL layer 218 made of an organic or inorganic material and a reflector electrode 219 made of metal are sequentially formed on a silica aerogel film 210 in the above mentioned order. Light 221 emitted from point 220 of the EL layer 218 is transmitted through the transparent electrode 217 and the silica aerogel film 210 to get to the interface 233 of the silica aerogel film 210 and the transparent substrate 211. Then, light 225 produced as a result of Fresnel reflection at the interface 233 is then propagated in the silica aerogel film 210 in the direction of regular reflection. The propagated light then goes into adjacent EL elements (not shown) and is randomly reflected by them before proceeding in the direction of observation. Thus, the propagated light that goes into adjacent EL elements can give rise to undesired noise in the latter. Additionally, the propagated light 225 constitutes a loss of light for the EL element from which it originates to consequently reduce the efficiency of effectively utilizing light.

[0080] FIG. 12 is a schematic cross sectional view of an electroluminescent element having a silica aerogel film formed on a transparent substrate and operating as a pixel in the seventh embodiment of display device according to the invention. In FIG. 12, the components that are same as or similar to those of FIGS. 7 and 11 are denoted respectively by the same reference symbols and will not be described any further.

[0081] In this embodiment, the silica aerogel film 210 has a size substantially same as that of the EL element 235. Light 227 emitted from point 226 of the EL layer 218 undergoes Fresnel reflection at the interface 234 of the silica aerogel film 210 and the transparent substrate 211 to become light 229, which is then reflected by the reflection film 330 formed on the surface of transparent member 340 to become light 230 that goes into air. Therefore, light that undergoes Fresnel reflection does not go into adjacent EL elements (not shown) nor totally reflected in the transparent substrate 211 to consequently raise the efficiency of utilization of light of this embodiment.

[0082] FIG. 13 is a schematic cross sectional view of an electroluminescent (EL) element having a low refractive index light transmitting film formed on a transparent substrate and operating as a pixel in the eighth embodiment of display device according to the invention.

[0083] Referring to FIG. 13, an insulating member is buried between any two adjacent electroluminescent (EL) elements in this embodiment. In FIG. 13, there are shown an EL layer 241, a transparent electrode 242 typically made of ITO, a reflector electrode 243 typically made of metal film, a low refractive index light transmitting film 244 typically made of silica aerogel, a reflection film 245, electrically conductive members 250 and 247, a thin film transistor (TFT) 246, a transparent substrate 249 typically made of glass and an insulating member 248 typically made of plastic such as polyimide and buried between the EL element and an adjacent EL element.

[0084] FIG. 14 is a schematic cross sectional view similar to FIG. 13 but illustrating the behavior of rays of light in the electroluminescent element. In FIG. 14, the components that are same as or similar to those of FIG. 13 are denoted respectively by the same reference symbols and will not be described any further.

[0085] Referring to FIG. 14, light 251 emitted from point 261 of the EL layer 241 directly strikes the top surface 270 of the transparent substrate 249 and goes into air as refracted light 252. On the other hand, light 256 emitted also from the point 261 is totally reflected by the interface of the transparent electrode 242 and the low refractive index light transmitting film 244 to become light 257, which is then reflected by the electrically conductive metal member 250 and goes into air as light 258. Finally, light 259 emitted from the point 261 and transmitted through the inside of the EL layer 241 is reflected by the electrically conductive metal film 250 formed on the slopes and goes into air as light 260. Note that a slight gap (not shown) is formed between the electrically conductive metal film 250 and the reflection film 245 of an adjacent EL element so that they may not contact each other at the apex of the triangle formed by them.

[0086] Meanwhile, in a display apparatus according to the invention, light emitted from each EL element is amplified when the EL layer comprising a hole/electron transport layer and the corresponding transparent electrode (anode) are sandwiched between a pair of mirrors and the light path length between the mirrors is made equal to the wavelength of light emitted from the EL layer to introduce the structure of a resonator into the EL element. Then, amplified light can be taken out by arranging a half mirror between the transparent substrate and the transparent electrode. Such an arrangement will be discussed below.

[0087] In the above described arrangement, the extent of increase G of the intensity of light emitted in a direction perpendicular to the transparent substrate depends on the reflectances of the mirrors, or the reflectance Rc of the reflection electrode (cathode) and the reflectance Rh of the half mirror and expressed by formula (1) below, which is shown in Monthly Display, October, 1998, p. 107.

$$G = (1 + (Rc)^2 \cdot (1 - Rh)) / (1 - (Rc \cdot Rh)^2) \quad (1)$$

[0088] If Rc is 90% and Rh is 0%, the value of G is 3.8 times greater than that of an ordinary EL element that does not have the structure of a resonator. If Rc is 90% and Rh is 85%, the value of G is 9.5 times greater than that of an EL element where Rc is 90% and Rh is 0%.

[0089] Additionally, the value of G can be raised or lowered depending on the values of Rc and Rh. Therefore,

a very bright display screen can be realized by introducing such a structure into a display device. When such a display device is placed in a light place, the viewers may feel it difficult to view the displayed image if the value of Rh is made large because both background light and room light are reflected. However, if such a display device is used in a dark place for a projector, neither background light nor room light give rise to any reflection problem. Therefore, the luminance of the image projected on a display screen by a projector can be increased when EL elements and half mirrors are combined to increase the intensity of light emitted in a direction perpendicular to the transparent substrate and the effect of the increased intensity of light and that of the increase in the quantity of light due to the transparent members and the reflection films as obtained in a display device according to the invention are combined.

[0090] FIG. 15 is a schematic cross sectional view of an electroluminescent (EL) element having a half mirror formed on a transparent substrate and operating as a pixel in the ninth embodiment of display device according to the invention. This embodiment differs from the first embodiment only in that a half mirror 160 is arranged between the transparent electrode 120 of each EL element and the transparent substrate 150. Otherwise, this embodiment is same and identical with the first embodiment. Therefore, in FIG. 15, the components that are same as or similar to those of FIG. 3 are denoted respectively by the same reference symbols and will not be described any further.

[0091] In this embodiment, the light path length between the reflector electrode 100 and the half mirror 160 is made equal to a half of the wavelength of light emitted from the EL element 300. Thus, these components form a resonator so that light can be taken out with an increased intensity. In this embodiment again, light totally reflected by the interfaces B1 and B2 is reflected by the reflection film 130 and emitted to the outside by way of the transparent substrate 150 to provide the advantage of increasing the efficiency of utilization of light as in the first embodiment.

[0092] FIG. 16 is a schematic cross sectional view of an electroluminescent (EL) element having a half mirror formed on a transparent substrate and operating as a pixel in the tenth embodiment of display device according to the invention. This embodiment differs from the fourth embodiment only in that a half mirror 160 is arranged between the transparent electrode 120 of each EL element and the transparent substrate 150. Otherwise, this embodiment is same and identical with the fourth embodiment. Therefore, in FIG. 16, the components that are same as or similar to those of FIG. 7 are denoted respectively by the same reference symbols and will not be described any further.

[0093] In this embodiment, the light path length between the reflector electrode 100 and the half mirror 160 is made equal to a half of the wavelength of light emitted from the EL element 300. Thus, these components form a resonator so that light can be taken out with an increased intensity. In this embodiment again, light totally reflected by the interfaces B1 and B2 is reflected by the reflection film 330 and emitted to the outside by way of the transparent substrate 150 to provide the advantage of increasing the efficiency of utilization of light as in the fourth embodiment.

[0094] The ninth and tenth embodiments can suitably be used for projectors for the above described reason. FIG. 17 is a conceptual illustration of a projector realized by using a display device shown in FIG. 15 or FIG. 16. In FIG. 17, reference symbol 400 denotes a display device comprising

EL elements having a configuration as shown in FIG. 15 or FIG. 16. The image of the display device 400 is projected onto a display screen 402 by way of a projection lens 401. With this arrangement, the projected image is by far brighter than the image produced by any comparable known system.

[0095] Referring to FIG. 15 and FIG. 16, the half mirror 160 typically has a four-layered structure of TiO₂ layer/SiO₂ layer/TiO₂ layer/SiO₂ layer. When the central wavelength of light emitted from the EL element is λ , the light path length of each of the layers is equal to $\lambda/4$. In the above described arrangement, the end SiO₂ layer is directly formed on the transparent substrate 150 by deposition.

[0096] Alternatively, the half mirror 160 may have a well known structure formed by repeatedly laying a pair of layers of TiO₂ layer/SiO₂ layer. With such an arrangement again, the end SiO₂ layer is directly formed on the transparent substrate 150 by deposition.

[0097] FIG. 18 is a schematic cross sectional view of a half mirror structure having eight layers realized by arranging four pairs of TiO₂ layer/SiO₂ layer. In FIG. 18, the layer denoted by ITO corresponds to the transparent electrode 120 in FIG. 15 or FIG. 16 and the layer denoted by G corresponds to the transparent substrate 150 in FIG. 15 or FIG. 16. Table 1 below shows some of the details of the films of the half mirror.

TABLE 1

$\lambda = 600 \text{ nm}$			
No.	mat.	n	d (nm)
0	G	1.46	
1	SiO ₂	1.485217	85
2	TiO ₂	2.298664	72
3	SiO ₂	1.485217	92
4	TiO ₂	2.298664	82
5	SiO ₂	1.485217	81
6	TiO ₂	2.298664	45
7	SiO ₂	1.485217	25
8	TiO ₂	2.298664	51
9	ITO	1.9	

[0098] FIG. 19 is a graph illustrating the reflectance of the above described half mirror structure of eight layers relative to light perpendicularly striking the half mirror.

[0099] FIGS. 20A through 20C are graphs illustrating the reflectance of a half mirror structure having eight layers in different aspects. FIG. 20A is a graph illustrating the reflectance of the above described half mirror structure having eight layers for S polarized light with a wavelength range between 400 nm and 700 nm and a range of angle of incidence within 30°. FIG. 20B is a graph illustrating the reflectance of the above described half mirror structure having eight layers for P polarized light with a wavelength range between 400 nm and 700 nm and a range of angle of incidence within 30°. FIG. 20C is a graph illustrating the average reflectance of the above described half mirror structure having eight layers for light with a wavelength range between 400 nm and 700 nm and a range of angle of incidence within 30°, or $\{(\text{reflectance for S polarized light}) + (\text{reflectance for P polarized light})\} / 2$.

[0100] Table 2 below shows the reflectance, the transmittance and the phases of reflected wave and transmitted wave of the above described half mirror structure having eight layers for light with an angle of incidence of 0°.

TABLE 2

theta	wl	Reflectance			Transmittance			Phase			
		(s) rs	(p) rp	(av) ra	(s) ts	(p) tp	(av) ta	(rs) prs-deg	(rp) prp-deg	(ts) pst-deg	(tp) ptp-deg
0	400	53.08212	53.08212	53.08212	46.91788	46.91788	46.91788	185.682	185.682	111.147	111.147
0	410	48.17657	48.17657	48.17657	51.82343	51.82343	51.82343	199.928	199.928	142.852	142.852
0	420	39.00835	39.00835	39.00835	60.99165	60.99165	60.99165	214.67	214.67	171.521	171.521
0	430	26.21536	26.21536	26.21536	73.78464	73.78464	73.78464	227.604	227.604	199.797	199.797
0	440	14.30588	14.30588	14.30588	85.69412	85.69412	85.69412	232.298	232.298	228.568	228.568
0	450	9.693069	9.693069	9.693069	90.30693	90.30693	90.30693	220.31	220.31	256.921	256.921
0	460	13.8806	13.8806	13.8806	86.1194	86.1194	86.1194	210.327	210.327	283.124	283.124
0	470	22.45843	22.45843	22.45843	77.54157	77.54157	77.54157	215.223	215.223	306.185	306.185
0	480	31.06662	31.06662	31.06662	68.93338	68.93338	68.93338	226.654	226.654	326.221	326.221
0	490	37.91265	37.91265	37.91265	62.08735	62.08735	62.08735	240.139	240.139	343.856	343.856
0	500	42.79684	42.79684	42.79684	57.20316	57.20316	57.20316	254.308	254.308	359.734	359.734
0	510	46.04912	46.04912	46.04912	53.95088	53.95088	53.95088	268.788	268.788	14.359	14.359
0	520	48.07543	48.07543	48.07543	51.92457	51.92457	51.92457	283.493	283.493	28.083	28.083
0	530	49.23057	49.23057	49.23057	50.76943	50.76943	50.76943	298.4	298.4	41.143	41.143
0	540	49.80049	49.80049	49.80049	50.19951	50.19951	50.19951	313.475	313.475	53.686	53.686
0	550	50.00978	50.00978	50.00978	49.99022	49.99022	49.99022	328.653	328.653	65.797	65.797
0	560	50.02995	50.02995	50.02995	49.97005	49.97005	49.97005	343.833	343.833	77.517	77.517
0	570	49.98419	49.98419	49.98419	50.01581	50.01581	50.01581	358.889	358.889	88.857	88.857
0	580	49.95105	49.95105	49.95105	50.04895	50.04895	50.04895	13.685	13.685	99.813	99.813
0	590	49.96959	49.96959	49.96959	50.03041	50.03041	50.03041	28.089	28.089	110.374	110.374
0	600	50.04673	50.04673	50.04673	49.95327	49.95327	49.95327	41.992	41.992	120.53	120.53
0	610	50.16668	50.16668	50.16668	49.83332	49.83332	49.83332	55.313	55.313	130.276	130.276
0	620	50.30027	50.30027	50.30027	49.69973	49.69973	49.69973	68.003	68.003	139.615	139.615
0	630	50.41309	50.41309	50.41309	49.58691	49.58691	49.58691	80.044	80.044	148.557	148.557
0	640	50.47114	50.47114	50.47114	49.52886	49.52886	49.52886	91.442	91.442	157.12	157.12
0	650	50.44449	50.44449	50.44449	49.55551	49.55551	49.55551	102.225	102.225	165.326	165.326
0	660	50.30878	50.30878	50.30878	49.69122	49.69122	49.69122	112.43	112.43	173.199	173.199
0	670	50.04538	50.04538	50.04538	49.95462	49.95462	49.95462	122.101	122.101	180.768	180.768
0	680	49.64119	49.64119	49.64119	50.35881	50.35881	50.35881	131.287	131.287	188.059	188.059
0	690	49.0876	49.0876	49.0876	50.9124	50.9124	50.9124	140.035	140.035	195.098	195.098
0	700	48.37985	48.37985	48.37985	51.62015	51.62015	51.62015	148.392	148.392	201.911	201.911

[0101] Table 3 below shows the reflectance of the above described half mirror structure having eight layers for S polarized light with a wavelength range between 400 nm and 700 nm, and a range of angle of incidence within 30°.

TABLE 3

theta	0	5	10	15	20	25	30
wl	rs(0°)	rs(5°)	rs(10°)	rs(15°)	rs(20°)	rs(25°)	rs(30°)
400	53.08212	53.3949	54.12334	54.48678	52.68927	45.05927	28.26013
410	48.17657	48.0306	47.21124	44.43833	37.23653	24.06525	26.01796
420	39.00835	38.22824	35.44011	29.42095	19.95582	18.17546	45.26679
430	26.21536	24.98771	21.19834	15.57016	14.30957	31.02331	59.49687
440	14.30588	13.43388	11.59921	12.37497	23.11551	45.36075	67.03681
450	9.693069	10.04325	12.33233	20.02936	35.63604	54.95319	70.74039
460	13.8806	15.35109	20.54906	30.85611	45.51777	60.55814	72.33646
470	22.45843	24.35017	30.22547	39.9916	52.03934	63.59624	72.73219
480	31.06662	32.88383	38.22425	46.44271	56.006	65.04069	72.45333
490	37.91265	39.47661	43.95743	50.6249	58.23293	65.50564	71.85011
500	42.79684	44.09124	47.75917	53.15198	59.31593	65.40039	71.17301
510	46.04912	47.11221	50.11556	54.53563	59.6761	65.01588	70.5896
520	48.07543	48.95622	51.45082	55.16329	59.61919	64.56017	70.18505
530	49.23057	49.97527	52.0999	55.32672	59.36993	64.16882	69.97028
540	49.80049	50.44935	52.32197	55.24517	59.08617	63.90939	69.90289
550	50.00978	50.59664	52.3144	55.07728	58.86468	63.79144	69.91378
560	50.02995	50.58197	52.22066	54.92683	58.74761	63.78334	69.92978
570	49.98419	50.5215	52.13468	54.84791	58.73335	63.8316	69.88688
580	49.95105	50.48664	52.10589	54.8533	58.79092	63.8771	69.73522
590	49.96959	50.50974	52.14688	54.92587	58.87459	63.86576	69.43871
600	50.04673	50.59212	52.24333	55.03077	58.93546	63.75335	68.97219
610	50.16668	50.71388	52.36478	55.12621	58.92895	63.50638	68.31834
620	50.30027	50.84343	52.47397	55.17116	58.81831	63.10088	67.46499
630	50.41309	50.94525	52.53369	55.12983	58.5754	62.52028	66.40318
640	50.47114	50.98534	52.51087	54.97339	58.17983	61.75344	65.12588

TABLE 3-continued

theta wl	0 rs(0°)	5 rs(5°)	10 rs(10°)	15 rs(15°)	20 rs(20°)	25 rs(25°)	30 rs(30°)
650	50.44449	50.93435	52.37858	54.6802	57.61763	60.79313	63.62755
660	50.30878	50.76881	52.11629	54.23494	56.8798	59.63484	61.90393
670	50.04538	50.47107	51.70927	53.62746	55.96098	58.2761	59.95224
680	49.64119	50.0289	51.14787	52.85181	54.85879	56.7164	57.77195
690	49.0876	49.43447	50.4264	51.90519	53.57301	54.95695	55.36522
700	48.37985	48.68366	49.54245	50.78745	52.1055	53.00111	52.73804

[0102] Table 4 below shows the reflectance of the above described half mirror structure having eight layers for S polarized light with a wavelength range between 400 nm and 700 nm and a range of angle of incidence within 30°.

TABLE 4

theta wl	0 rp(0°)	5 rp(5°)	10 rp(10°)	15 rp(15°)	20 rp(20°)	25 rp(25°)	30 rp(30°)
400	53.08212	52.41265	50.11352	45.19735	35.91914	21.38051	7.714678
410	48.17657	47.0462	43.25155	35.67732	23.52558	10.47469	6.09405
420	39.00835	37.32218	31.98673	22.77523	12.0694	7.138141	10.295
430	26.21536	24.31187	18.8981	11.84362	8.091181	11.22493	15.63376
440	14.30588	13.04836	10.26356	8.979772	12.20714	17.95092	19.73183
450	9.693069	9.706433	10.6241	14.08498	19.74767	23.95304	22.1791
460	13.8806	14.77373	17.64994	22.30504	26.88842	28.21266	23.30821
470	22.45843	23.49275	26.33542	29.93909	32.27244	30.82653	23.60357
480	31.06662	31.84632	33.79384	35.73271	35.86257	32.20508	23.49964
490	37.91265	38.35183	39.29464	39.68754	38.02603	32.77816	23.31682
500	42.79684	42.93243	43.01936	42.17475	39.17749	32.90971	23.24601
510	46.04912	45.94468	45.36773	43.59799	39.67931	32.87423	23.36023
520	48.07543	47.79115	46.72505	44.30494	39.82129	32.85165	23.64426
530	49.23057	48.81779	47.41154	44.57511	39.81848	32.93333	24.03153
540	49.80049	49.30242	47.68153	44.62272	39.81271	33.13805	24.43688
550	50.00978	49.46244	47.73026	44.60017	39.87867	33.43479	24.77926
560	50.02995	49.46219	47.69869	44.60206	40.03564	33.76629	24.99371
570	49.98419	49.41716	47.67725	44.67203	40.26349	34.0683	25.03518
580	49.95105	49.39789	47.71136	44.81339	40.51962	34.28204	24.87747
590	49.96959	49.4358	47.80998	45.00217	40.75334	34.36063	24.51025
600	50.04673	49.53148	47.95609	45.19974	40.9159	34.27074	23.93544
610	50.16668	49.66448	48.11768	45.3632	40.96618	33.9918	23.16418
620	50.30027	49.80294	48.25693	45.45234	40.8728	33.51408	22.2142
630	50.41309	49.91129	48.33689	45.43338	40.61411	32.83644	21.10787
640	50.47114	49.95562	48.32522	45.28025	40.17702	31.96444	19.87064
650	50.44449	49.90677	48.19603	44.97455	39.55558	30.90882	18.52991
660	50.30878	49.74154	47.93003	44.50458	38.74951	29.68432	17.11396
670	50.04538	49.44257	47.51391	43.8641	37.76299	28.30877	15.65106
680	49.64119	48.99798	46.93955	43.05153	36.60391	26.80261	14.1688
690	49.0876	48.4003	46.20294	42.06877	35.28305	25.18815	12.69317
700	48.37985	47.64581	45.3035	40.92075	33.81384	23.48918	11.24807

[0103] Table 5 below shows the average reflectance of the above described half mirror structure having eight layers for light with a wavelength range between 400 nm and 700 nm and a range of angle of incidence within 30°, or $\{(reflectance \text{ for S polarized light})+(reflectance \text{ for P polarized light})\}/2$.

TABLE 5

theta wl	0 ra(0°)	5 ra(5°)	10 ra(10°)	15 ra(15°)	20 ra(20°)	25 ra(25°)	30 ra(30°)
400	53.08212	52.90377	52.11843	49.84207	44.30421	33.21989	17.9874
410	48.17657	47.5384	45.2314	40.05782	30.38105	17.26997	16.056
420	39.00835	37.77521	33.71342	26.09809	16.01261	12.6568	27.7809
430	26.21536	24.64979	20.04822	13.70689	11.20038	21.12412	37.56531

TABLE 5-continued

theta wl	0 ra(0°)	5 ra(5°)	10 ra(10°)	15 ra(15°)	20 ra(20°)	25 ra(25°)	30 ra(30°)
440	14.30588	13.24112	10.93139	10.67737	17.66133	31.65583	43.38432
450	9.693069	9.874841	11.47822	17.05717	27.69186	39.45311	46.45974
460	13.8806	15.06241	19.0995	26.58057	36.20309	44.3854	47.82233
470	22.45843	23.92146	28.28045	34.96535	42.15589	47.21139	48.16788
480	31.06662	32.36507	36.00905	41.08771	45.93428	48.62288	47.97648
490	37.91265	38.91422	41.62603	45.15622	48.12948	49.1419	47.58346
500	42.79684	43.51183	45.38926	47.66336	49.24671	49.15505	47.20951
510	46.04912	46.52845	47.74164	49.06681	49.67771	48.94506	46.97491
520	48.07543	48.37368	49.08793	49.73411	49.72024	48.70591	46.91465
530	49.23057	49.39653	49.75572	49.95092	49.5942	48.55107	47.00091
540	49.80049	49.87589	50.00175	49.93394	49.44944	48.52372	47.16988
550	50.00978	50.02954	50.02233	49.83873	49.37168	48.61311	47.34652
560	50.02995	50.02208	49.95967	49.76445	49.39162	48.77482	47.46174
570	49.98419	49.96933	49.90597	49.75997	49.49842	48.94995	47.46103
580	49.95105	49.94226	49.90863	49.83334	49.65527	49.07957	47.30635
590	49.96959	49.97277	49.97843	49.96402	49.81396	49.1132	46.97448
600	50.04673	50.0618	50.09971	50.11525	49.92568	49.01204	46.45381
610	50.16668	50.18918	50.24123	50.24471	49.94756	48.74909	45.74126
620	50.30027	50.32318	50.36545	50.31175	49.84555	48.30748	44.8396
630	50.41309	50.42827	50.43529	50.28161	49.59476	47.67836	43.75552
640	50.47114	50.47048	50.41805	50.12682	49.17843	46.85894	42.49826
650	50.44449	50.42056	50.2873	49.82738	48.58661	45.85097	41.07873
660	50.30878	50.25518	50.02316	49.36976	47.81466	44.65958	39.50894
670	50.04538	49.95682	49.61159	48.74578	46.86198	43.29243	37.80165
680	49.64119	49.51344	49.04371	47.95167	45.73135	41.75951	35.97038
690	49.0876	48.91739	48.31467	46.98698	44.42803	40.07255	34.0292
700	48.37985	48.16473	47.42298	45.8541	42.95967	38.24515	31.99305

[0104] As shown above, the reflectance of the above described half mirror having eight layers is substantially constant and about 50% for visible light with a range of angle of incidence within 30°. According to the formula (1) described earlier, the increase G in the intensity of light is about 17 times greater than that of an ordinary element having no resonator structure when Rc is 90% and Rh is 50%. Therefore, the quantity of light at the image forming surface is increased by 17 times when a display device comprising half mirrors is used for a projector and NA=sin 30°, or the lens is used with a full aperture of F number=1.

[0105] Note that the light path length between the half mirror 160 having four or eight layers and the reflector electrode 100 is made equal to ½ of the wavelength of light emitted from the EL element in the embodiments of FIGS. 15 and 16. However, it may alternatively be made equal to integer times of ½ of the wavelength of emitted light.

[0106] Besides, since the cathode, or the reflector electrode 100, is made of metal such as aluminum (Al), it reflects not only light from the EL layer 110 also external light directed to the viewer. However, as external light is reflected, the contrast of the image displayed on the display screen of the display device is reduced. In other words, the reflection of external light needs to be eliminated or minimized. Japanese Patent Application Laid-Open No. 8-8065 discloses an arrangement for reducing external light by making the cathode have two-layered structure, realizing the EL layer 110 as a light absorbing layer and arranging another electrode layer typically made of aluminum (Al).

[0107] FIG. 21 is a schematic cross sectional view of an electroluminescent (EL) element having a light absorbing layer formed on a transparent substrate and operating as a pixel in the eleventh embodiment of display device according to the invention. This embodiment differs from the above

described ninth embodiment only in that a light absorbing layer 100a is formed between the EL layer 110 and the reflector electrode 100 of each EL element 300. Otherwise, this embodiment is identical with the ninth embodiment. Therefore, in FIG. 21, the components that are same as or similar to those of FIG. 15 are denoted respectively by the same reference symbols and will not be described any further.

[0108] In this embodiment, total reflection is realized at the interface of the light absorbing layer 100a and the EL layer 110 by making the refractive index of the light absorbing layer 100a located at a side of the EL layer lower than that of the EL layer 110. With this arrangement, light is totally reflected to return into the EL layer and reflected again by the reflection film 130 to consequently increase the proportion of light emitted to the outside from the display device.

[0109] When the EL layer 110 is made of aluminum quinolinol (alq), its refractive index will be about 1.73. Therefore, then, the light absorbing layer 100a is preferably made of MgO having a refractive index of 1.70. If the EL layer 110 comprises an electron transport layer, the refractive index of the light absorbing layer 100a needs to be made lower than that of the electron transport layer.

[0110] Referring to FIG. 21, light 1003 emitted from the EL layer 110 is totally reflected by the interface of the light absorbing layer 100a and the EL layer 110 to become light 1004, which is then reflected by the reflection film 130 to become light 1005 and go out of the display device.

[0111] FIG. 22 is a schematic cross sectional view of an electroluminescent (EL) element having a light absorbing layer in the twelfth embodiment of display device according to the invention. This embodiment differs from the above

described tenth embodiment only in that a light absorbing layer **100a** is formed between the EL layer **110** and the reflector electrode **100** of each EL element **300**. Otherwise, this embodiment is identical with the tenth embodiment. Therefore, in **FIG. 22**, the components that are same as or similar to those of **FIG. 16** are denoted respectively by the same reference symbols and will not be described any further.

[0112] The light absorbing layer **100a** of this embodiment is preferably made of a material same as its counterpart of the eleventh embodiment. Referring to **FIG. 22**, light **1003** emitted from the EL layer **110** is totally reflected by the interface of the light absorbing layer **100a** and the EL layer **110** to become light **1004**, which is then reflected by the reflection film **330** to become light **1005** and go out of the display device.

[0113] As described above in detail, according to the invention, it is no longer necessary to arrange a protection film for shielding each EL element from ambient air after forming the transparent members. Nor is it necessary to design the manufacturing steps in such a way that, when a reflection film is formed on each transparent member, it is arranged so as not to contact the transparent electrode and the reflector electrode that sandwich the reflection film. Thus, it is possible to simplify the manufacturing steps and reduce the manufacturing cost. Therefore, according to the invention, the transparent members protect the EL elements from ambient air and light emitted from the EL layer of each EL element can be efficiently taken out to the outside by the reflection film formed on the corresponding transparent member.

[0114] The present invention is by no means limited to the above described embodiments, which may be modified or altered in various different ways without departing from the spirit or scope of the general inventive concept as defined by the appended claims and their equivalents.

What is claimed is:

1. A display device comprising:
 - a transparent substrate;
 - a plurality of electroluminescent elements arranged on said transparent substrate, each of said electroluminescent elements being formed by sequentially laying a transparent electrode, an electroluminescent layer and a reflector electrode on said transparent substrate;
 - transparent members having a profile of a frustum of pyramid or cone and respectively covering said electroluminescent elements; and
 - reflection films formed respectively on the surfaces of said transparent members.
2. A display device according to claim 1, further comprising:
 - a plurality of drive elements arranged to drive the respective corresponding electroluminescent elements to emit light;
 - said drive element being coated respectively with said transparent members.
3. A display device according to claim 2, further comprising:

an insulating body filling the gaps separating said transparent members and wires formed on said insulating body;

said drive elements being connected respectively to said wires.

4. A display device according to claim 1, further comprising:

an insulating body filling the gaps separating said transparent members and wires formed on said insulating body;

said reflector electrodes and said transparent electrodes of said electroluminescent elements being connected respectively to said wires.

5. A display device according to claim 1, wherein

each of said electroluminescent elements comprises a half mirror arranged between said transparent substrate and said transparent electrode;

the light path length between said half mirror and said reflector electrode being integer times of $\frac{1}{2}$ of the wavelength of light emitted from said electroluminescent element.

6. A display device according to claim 5, wherein

the light path length between said half mirror and said reflector electrode is equal to the wavelength of light emitted from said electroluminescent element.

7. A display device according to claim 1, wherein

each of said electroluminescent elements further comprises a light absorbing layer arranged between said reflector electrode and said electroluminescent layer and having a refractive index lower than that of said electroluminescent layer.

8. A display device according to claim 7, wherein

the electroluminescent layer of each of said electroluminescent elements includes an electron transport layer arranged at the side of said reflector electrode and the refractive index of said light absorbing layer is lower than that of said electron transparent layer.

9. A display device according to claim 1, wherein

each of said electroluminescent elements further comprises a silica aerogel film layer arranged between said transparent substrate and said transparent electrode.

10. A display device according to claim 1, wherein

each of said electroluminescent elements has an air gap formed between said transparent substrate and said transparent electrode.

11. A display device comprising:

a transparent substrate;

a plurality of electroluminescent elements arranged on said transparent substrate, each of said electroluminescent elements being formed by sequentially laying a transparent electrode, an electroluminescent layer and a reflector electrode on said transparent substrate;

transparent members respectively covering said electroluminescent elements, each of said transparent members partly having a curved surface showing a positive curvature, a part thereof held in contact with said transparent substrate having a curved surface showing a negative curvature; and

reflection films formed respectively on the surfaces of said transparent members.

12. A display device according to claim 11, wherein

each of said reflection film operates as a concave mirror relative to the corresponding electroluminescent element and the focal plane of the concave mirror is located within said electroluminescent element.

13. A display device according to claim 11, further comprising:

a plurality of drive elements arranged to drive the respective corresponding electroluminescent elements to emit light;

said drive element being coated respectively with said transparent members.

14. A display device according to claim 13, further comprising:

an insulating body filling the gaps separating said transparent members and wires formed on said insulating body;

said drive elements being connected respectively to said wires.

15. A display device according to claim 11, further comprising:

an insulating body filling the gaps separating said transparent members and wires formed on said insulating body;

said reflector electrodes and said transparent electrodes of said electroluminescent elements being connected respectively to said wires.

16. A display device according to claim 11, wherein

each of said electroluminescent elements comprises a half mirror arranged between said transparent substrate and said transparent electrode;

the light path length between said half mirror and said reflector electrode being integer times of $\frac{1}{2}$ of the wavelength of light emitted from said electroluminescent element.

17. A display device according to claim 16, wherein

the light path length between said half mirror and said reflector electrode is equal to the wavelength of light emitted from said electroluminescent element.

18. A display device according to claim 11, wherein

each of said electroluminescent elements further comprises a light absorbing layer arranged between said reflector electrode and said electroluminescent layer and having a refractive index lower than that of said electroluminescent layer.

19. A display device according to claim 18, wherein

the electroluminescent layer of each of said electroluminescent elements includes an electron transport layer arranged at the side of said reflector electrode and the refractive index of said light absorbing layer is lower than that of said electron transparent layer.

20. A display device according to claim 11, wherein

each of said electroluminescent elements further comprises a silica aerogel film layer arranged between said transparent substrate and said transparent electrode.

21. A display device according to claim 11, wherein

each of said electroluminescent elements has an air gap formed between said transparent substrate and said transparent electrode.

* * * * *

专利名称(译)	显示设备		
公开(公告)号	US20020105267A1	公开(公告)日	2002-08-08
申请号	US09/993672	申请日	2001-11-27
[标]申请(专利权)人(译)	望月德隆蒂 德田龙二 SETANI道隆 SAKURANAGA MASANORI HOSHI HIKARU		
申请(专利权)人(译)	望月德隆蒂 德田龙二 SETANI道隆 SAKURANAGA MASANORI HOSHI HIKARU		
当前申请(专利权)人(译)	佳能株式会社		
[标]发明人	MOCHIZUKI NORITAKA TOKUDA RYUJI SETANI MICHITAKA SAKURANAGA MASANORI HOSHI HIKARU		
发明人	MOCHIZUKI, NORITAKA TOKUDA, RYUJI SETANI, MICHITAKA SAKURANAGA, MASANORI HOSHI, HIKARU		
IPC分类号	H05B33/02 G09F9/30 H01L27/32 H01L51/50 H01L51/52 H05B33/00 H05B33/04 H05B33/22 H05B33/24 H01J63/04		
CPC分类号	H01L51/5237 H01L51/5262 H05B33/00 H01L51/5253		
优先权	2001189722 2001-06-22 JP 2001306539 2001-10-02 JP 2000370647 2000-12-05 JP 2000398283 2000-12-27 JP 2001062055 2001-03-06 JP		
其他公开文献	US6858983		
外部链接	Espacenet USPTO		

摘要(译)

一种显示装置，包括透明基板，设置在透明基板上的多个电致发光元件，分别覆盖电致发光元件的透明构件，以及分别形成在透明构件表面上的反射膜。通过在透明基板上依次铺设透明电极，电致发光层和反射电极来形成每个电致发光元件。每个透明构件具有金字塔或锥体的平截头体的轮廓，或者部分地具有示出正曲率的曲面并且具有在与透明基板保持接触的部分处显示负曲率的曲面。

